

ITEM	DESCRIPTION	CODE	QTY.	R.S./100
1	3/4 H.P. MONOPHASE MOTOR (IMPORT.)	05-00180	1	2
1	3/4 H.P. MONOPHASE MOTOR (NAT.)	05-01306	1	2
1	3/4 H.P. MONOPHASE MOTOR (IMPORT.) AND CAPACITOR-HARNESS	05-73234	1	2
1	3/4 H.P. MONOPHASE MOTOR (NAT.) AND CAPACITOR-HARNESS	05-73235	1	2
2	SEAL 5946	05-00189	1	4
3	GEAR BOX KIT M-12FS	05-73232	1	2
4	SEAL 12356	05-00188	1	2
5	GEAR COVER KIT M-12FS	05-73233	1	2
6	GASKET	05-00146	1	4
7	PIN 3/16"x 1 1/4"	05-01588	2	2
8	SQUARE GEAR KIT (180 RPM 60Hz)	05-71897	1	2
8	SQUARE GEAR KIT (180 RPM 50Hz)	05-73226	1	2
9	DOUBLE ROD GEAR (180 RPM 60Hz)	05-72180	1	2
9	DOUBLE ROD GEAR (180 RPM 50Hz)	05-71351	1	2
10	GEAR (PINION)	05-70193	1	2
11	GEAR (FLAT)	05-71162	1	2
12	WOODRUFF KEY #405-5	05-00296	1	2
13	KEY 3/16"x 3/16" x 3/4"	05-70010	1	2
14	GEAR (SQUARE) CAP	05-00329	1	2
15	BOLT HEX. HEAD 3/8"x 1 1/4" AND WASHERS KIT	05-72819	4	2
16	BOLT HEX. HEAD 5/16"x 1 1/4"	05-00408	6	2
17	BRONZE BUSHING	05-70395	1	4
18	BRONZE BUSHING	05-00131	2	4
19	5/16"x 3/4" S.S. PIN	05-01134	1	2
	GEAR KIT (180 R.P.M. 60Hz), INCLUDES ITEMS 8 THROUGH 13.	05-72223	1	1
	GEAR KIT (180 R.P.M. 50Hz), INCLUDES ITEMS 8 THROUGH 13.	05-73223	1	1

R.S. = REQUIREMENT STOCK

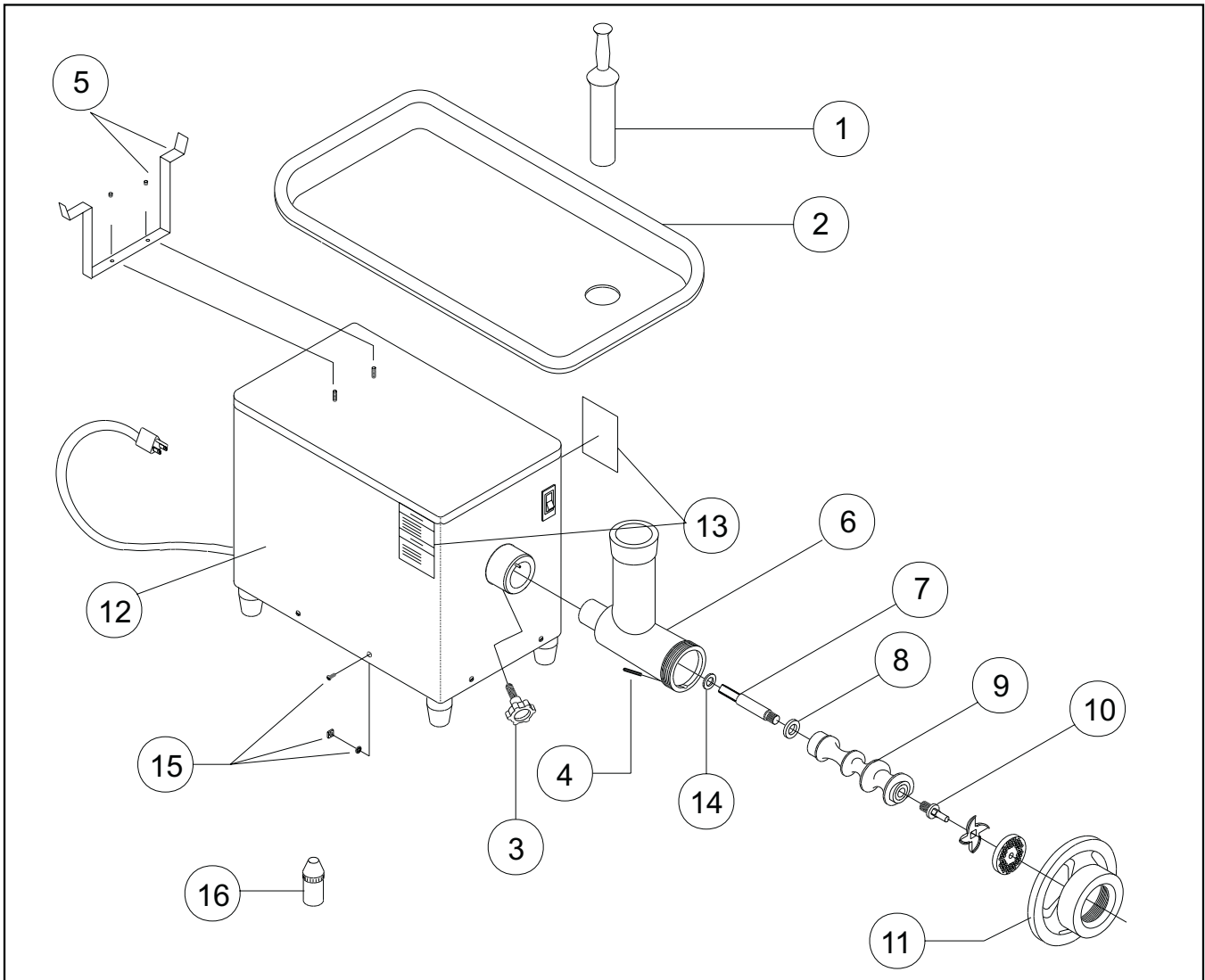

ITEM	DESCRIPTION	CODE	QTY.	R.S./100
1	STOMPER (SOLID) M-12FS	05-01604	1	10
2	TRAY S.S. M-12FS	05-72898	1	2
3	HEADSTOCK KNOB	05-02270	1	2
4	PIN 5/32"x 1 11/16"	05-70227	1	20
5	SUPPORT TRAY S.S. AND NUTS	05-73236	2	2
6	HEADSTOCK, PIN AND BRONZE WASHER M-12FS	05-72895	1	2
7	REAR ROD	05-02168	1	2
8	NYLON WASHER	05-00344	1	100
9	FEED SCREW (WORM)	05-70480	1	2
10	FRONT ROD	05-02166	1	10
11	HEADSTOCK RING	05-70380	1	1
12	CASE AND THERMIC-ISOLATING ASSY. M-12FS	05-71179	1	1
13	WARNING DECAL	05-01258	2	2
14	BRONZE WASHER	05-70389	1	2
15	SCREW, NUT, AND WASHER 3/16"	05-72224	8	8
16	GREASE FDA APPROVED	05-01572	1	4

FEED SCREW (WORM) KIT INCLUDES ITEMS 7 THROUGH 10.
 R.S.= REQUIREMENT STOCK

05-70480 1 10

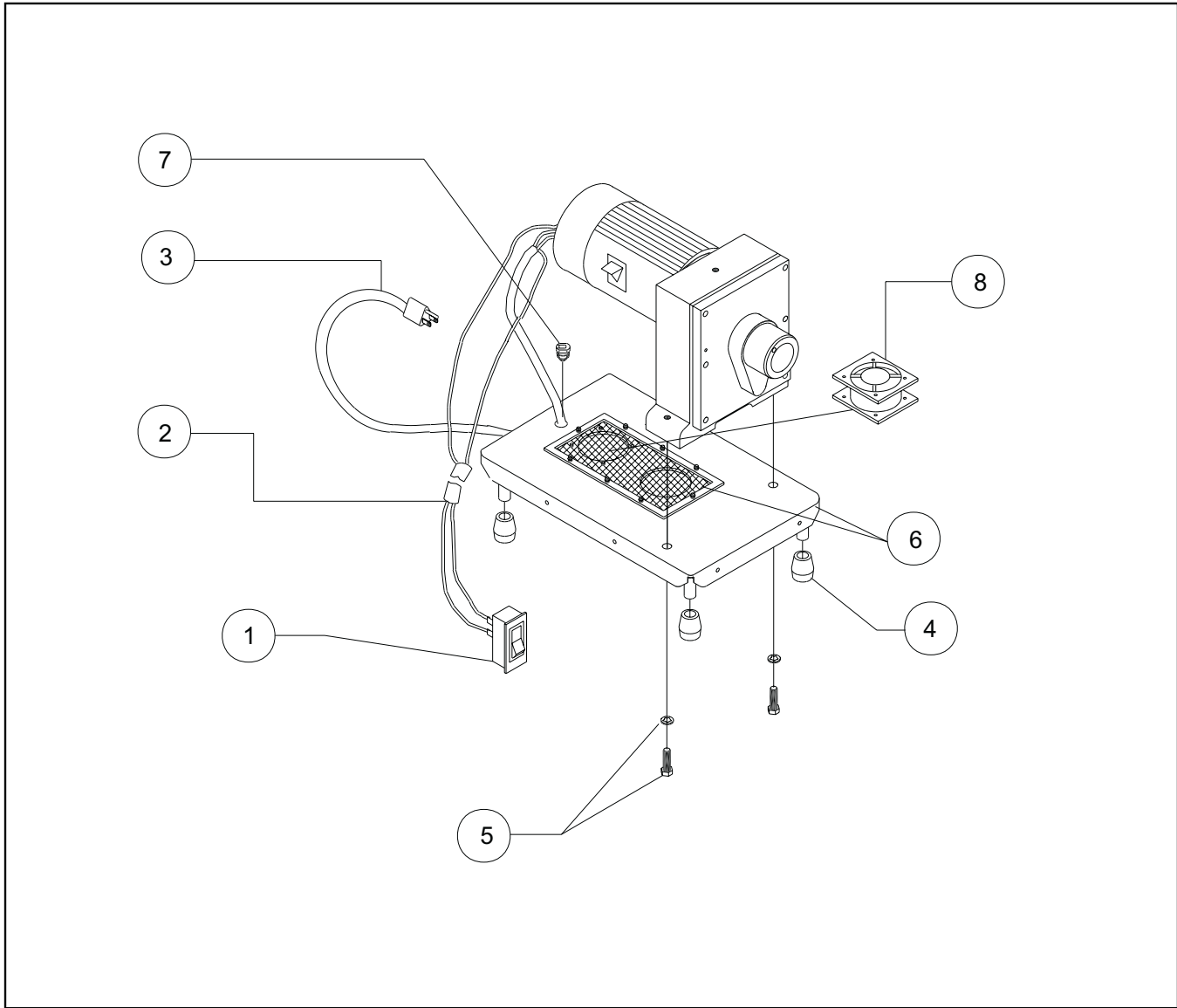

ITEM	DESCRIPTION	CODE	QTY.	R.S./100
1	SWITCH 1600H-11E	05-01802	1	4
2	HARNESS CABLE 1331	05-00850	1	2
3	POWER CORD	05-00154	1	2
4	RUBBER PLUG-PAD	05-00334	4	2
5	BOLT HEX. HEAD 7/16"x 1 1/4" AND WASHER	05-71904	2	2
6	BASE AND WIRE FABRIC ASSY.	05-72849	1	2
7	GROMMET 7P-2	05-00799	1	2
8	FAN 115V	05-01291	1	2

USE TRANSMISSION OIL SAE #140 3/4 LT.

R.S.= REQUIREMENT STOCK