

AFMG 400-66

PARTS
BREAKDOWN

PARTS DIAGRAM

65288 ELECTRICAL ASSEMBLY
 65126 PNEUMATIC ASSEMBLY
 65243 SHIPPING PALLET
 66000-66M OWNERS MANUAL

LABELS:

- 1) 66069 CONTROL PANEL
- 1) 90880 GREASE
- 3) 30259 HANDS OUT HOPPER
- 2) 66113 AFMG 400-66
- 1) 90586 SERIAL TAG
- 2) 90894-01 208 VOLT
- 90894-02 230 VOLT
- 90894-03 460 VOLT
- 1) 66072 FROZEN MEAT
- 1) 62113 ROTATION
- 2) 90789 DFE
- 1) 90091 DANGER MOVING
- 1) 90084 DANGER ELECTRICAL
- 2) 90089 USA
- 1) 90085 WARNING

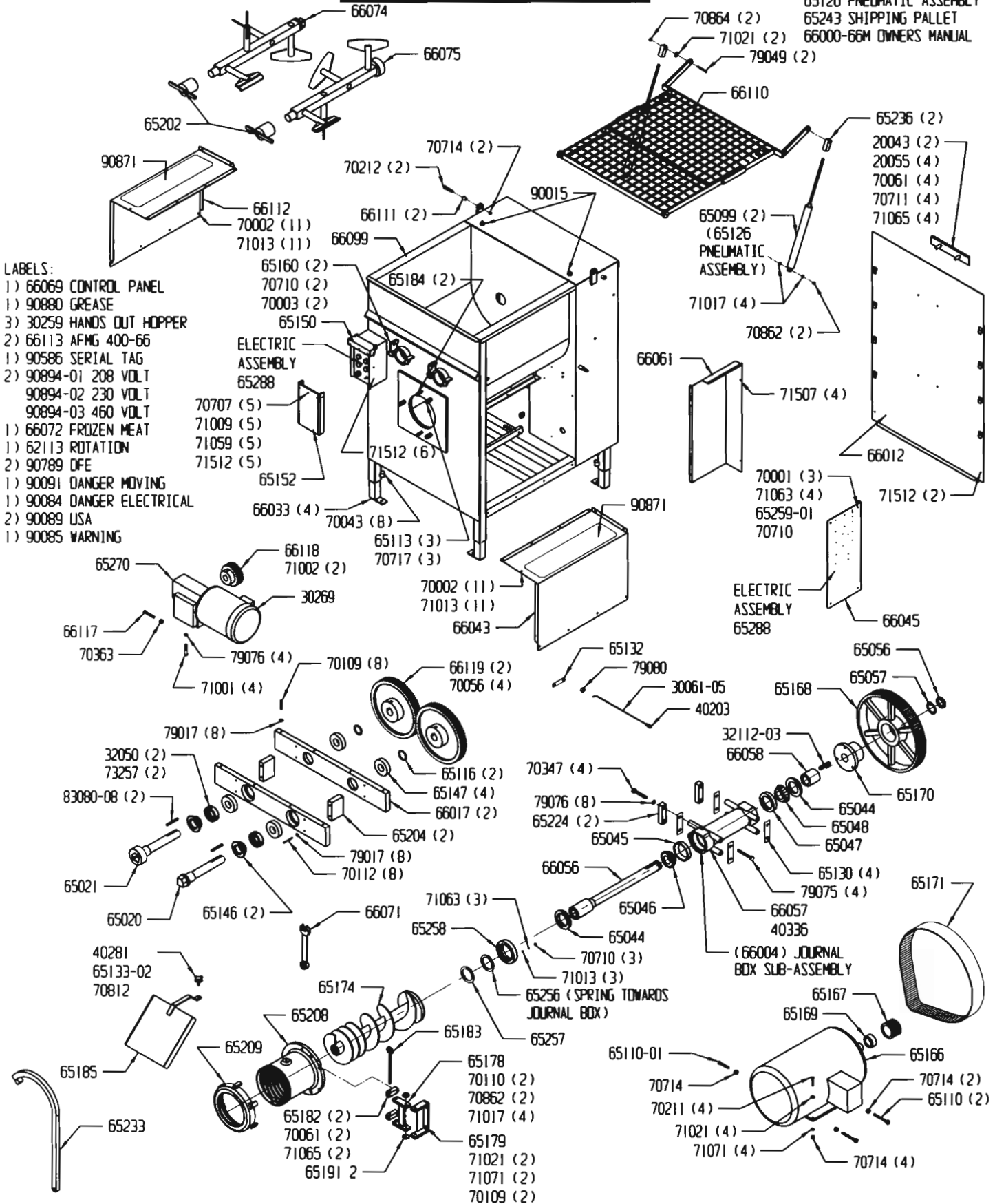

PARTS LIST

ITEM #	PART #	DESCRIPTION	QTY	ITEM #	PART #	DESCRIPTION	QTY
1	20043	HANDLE	2	61	66074	FEMALE PADDLE	1
2	20055	HANDLE SPACER	4	62	66075	MALE PADDLE	1
3	30061-05	GREASE TUBE	1	63	66099	HOPPER TO FRAME XMNT	1
4	30259	DECAL HANDS OUT HOPPER	1	64	66102	ACCESS COVER	1
5	30269	5HP MOTOR 131492	1	65	66110	LID ASSEMBLY	1
6	32050	SEAL NUT	2	66	66111	LID BUSHING	2
7	40203	GREASE ZERK	1	67	66112	MOTOR COVER LEFT	1
8	40281	KNOB	1	68	66113	AFMG 400-66 DECAL	2
9	62113	ROTATION LABEL	1	69	66117	ADJUSTING BOLT	1
10	65020	MALE DRIVE SHAFT XMNT.	1	70	66118	20 TOOTH GEAR	1
11	65021	FEMALE DRIVE SHAFT	1	71	66119	60 TOOTH GEAR	2
12	65110	MOTOR ADJUSTING ROD	2	72	70001	1/4-20 X 1/2" SS BOLT	3
13	65110-01	MOTOR ADJUSTING ROD	1	73	70002	1/4 -20 X 5/8" BOLT	22
14	65113	BOWL MOUNTING STUD	3	74	70003	1/4-20 X 3/4" BOLT SS	2
15	65116	WASHER - MODIFIED	2	75	70043	SET SCREW 3/8 X 1-1/2	8
16	65126	PNEUMATIC ASSEMBLY	1	76	70056	1/2-13 X 2" SET SCREW	4
17	65130	JOURNAL BOX SHIMS	4	77	70061	5/16-18 X 2 BOLT	6
18	65132	GREASE TUBE HOLDER	1	78	70109	3/8-16 X 1-1/2" BOLT	8
19	65133-02	3/8 X 1-3/16 REDI ROD	1	79	70110	3/8-16 X 1-3/4" SS BOLT	2
20	65146	PADDLE SEAL	2	80	70112	3/8-16 X 2-1/4" BOLT	8
21	65147	BEARINGS	4	81	70211	1/2-13 X 2 BOLT	4
22	65150	CONTROL COVER TOP	1	82	70212	1/2-13 X1-3/4" SS BOLT	4
23	65152	CONTROL COVER	1	83	70347	5/8-18 X 3-1/2" BOLT SS	4
24	65160	SAFETY LATCH	2	84	70363	1/2-13 SS JAM NUT	1
25	65166	20 HP MOTOR	1	85	70707	10-24 NUT SS	5
26	65167	SPROCKET 38T	1	86	70710	1/4-20 NUT SS	6
27	65168	SPROCKET 192T	1	87	70711	5/16-18 NUT SS	4
28	65169	BUSHING 1-1/78	1	88	70714	1/2-13 NUT SS	9
29	65170	BUSHING 2	1	89	70717	3/4-10 NUT SS	3
30	65171	BELT	1	90	70812	3/8-16 JAM NUT	1
31	65174	AUGER ASSEMBLY	1	91	70862	3/8-16 NYLOCK	4
32	65178	HINGE XMNT MOVABLE	1	92	70864	1/2-13 NYLOCK	2
33	65179	HINGE XMNT STATIONARY	1	93	71001	5/8-11 X 1-1/2" CAP BOLT	4
34	65182	BOWL HINGE MOUNT	2	94	71002	1/2-13 X 3/4" SET SCREW	2
35	65183	BOWL HINGE PIN	1	95	71009	#10 FLAT WASHER	5
36	65184	BOWL GUIDE PIN	2	96	71013	1/4" FLAT WASHER	25
37	65185	SPLASH GUARD	1	97	71017	3/8" FLAT WASHER SS	8
38	65191	BOWL HINGE BUSHING	2	98	71021	1/2" FLAT WASHER SS	8
39	65202	PADDLE LOCK ASSEMBLY	2	99	71059	#10 LOCK WASHER	5
40	65204	BEARING BLOCK SPACER	2	100	71063	1/4" LOCK WASHER SS	7
41	65208	GRINDER BOWL	1	101	71065	5/16 LOCK WASHER	6
42	65209	RING	1	102	71071	1/2" SS LOCK WASHER	6
43	65223	RING WRENCH	1	103	71507	10-24 X 3/8" SS SCREW	4
44	65224	JOURNAL BOX SPACER	2	104	71512	10-24 X 1/2 SCREW	13
45	65243	SHIPPING PALLET	1	105	73257	1/4-20 SET SCREW	2
46	65256	AUGER DRIVE SHAFT SEAL	1	106	79017	3/8" LOCK WASHER ZINC	16
47	65257	SEAL GUARD	1	107	79049	1/2-13 X 2-1/4" BOLT	2
48	65258	SEAL RETAINER	1	108	79075	5/8-18 X 2" BOLT	4
49	65259-01	1/4-20 X 3/4" STUD	1	109	79076	5/8" LOCK WASHER	12
50	65269	BOWL PIN	1	110	79080	1/2-13 ZINC NUT	1
51	65270	935 GEAR BOX	1	111	83080-08	KEY	2
52	65288	ELECTRICAL ASSEMBLY	1	112	90084	DANGER DECAL, ELECT	1
53	66000-66M	OWNERS MANUAL	1	113	90085	WARNING DECAL	1
54	66004	JOURNAL BOX ASSEMBLY	1	114	90089	MADE IN USA DECAL	2
55	66017	BEARING BLOCK	2	115	90091	DANGER DECAL, PARTS	1
56	66033	ADJUSTABLE LEG	4	116	90586	I.D. DECAL	1
57	66043	MOTOR COVER RIGHT	1	117	90789	DFE LOGO	2
58	66061	ELECTRICAL COVER	1	118	90871	ANTISLIP ADHESIVE	2
59	66071	1-1/8" WRENCH	1	119	90880	DECAL GREASE	1
60	66072	LABEL FROZEN PRODUCT	1	120	90894-02	DECAL 230 VOLT	1

PNEUMATIC SCHEMATIC

PART #	DESCRIPTION	QTY
90927	AIR CONTROL VALVE	1
65099	AIR CYLINDER	2
65236	AIR CYLINDER END	2
90933	EXHAUST FLOW CONT	2
90930	CONTROL VALVE KNOB	1
90500	HOSE 1/4"	20'
90567	TEE	2
90581	1/8" NPT STRAIGHT	2
90928	BULK HEAD	1
90931	AIR VALVE	1
90874	5/32" HOSE	10'
90934	1/8" NPT 90°	4
90877	1/4 TO 5/32 REDUCER	1
90878	5/32 TUBE X 10-32	1
90876	1/4 TUBE X 1/8 NPT	1
90887	1/4 TUBE TO 1/4 NPT	1
90870	1/4 X 3/16 GROMMET	4
71607	10-32 SCREW	2

66067 OPTIONAL AIR COMPRESSOR.
NEED (1) 90352 ON COMPRESSOR OUTLET
AND 55' OF 90874 HOSE.
DON'T NEED 90928 OR 90887

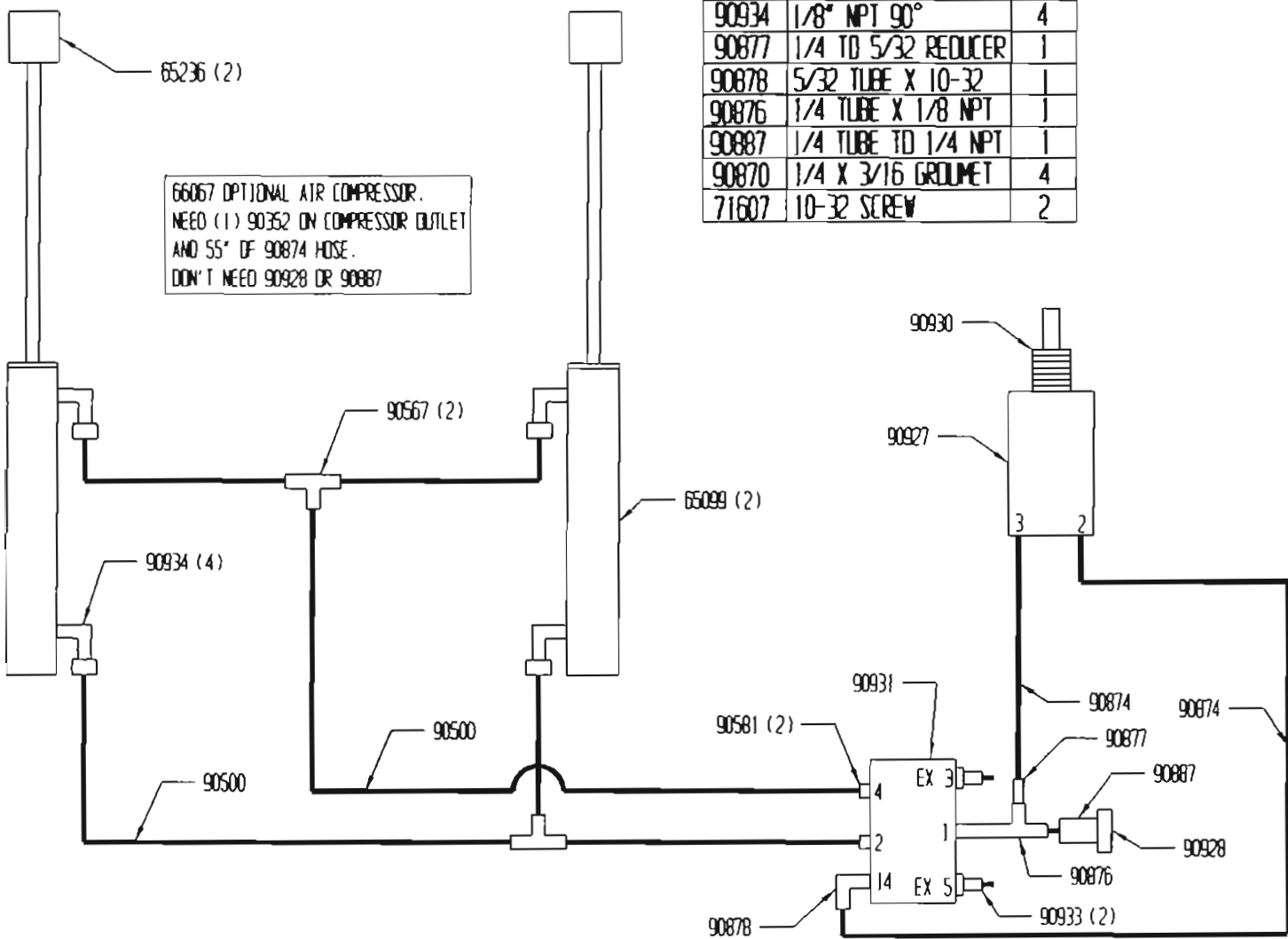

ELECTRICAL SCHEMATIC

